

# YAMAHA RX-950 *RS*

*Natural Sound Stereo Receiver*

*120W + 120W (8Ω) RMS Output Power, 0.015% THD, 20–20,000 Hz*

*40-Station Random Preset Tuning*

*IF Count Direct PLL Synthesizer Tuning System*

*Continuously Variable Loudness Control*

*High Dynamic Power, Low Impedance Drive Capability*

*Pure Direct Switch to Reproduce the Purest Source Sound*

*Sleep Timer*

*Remote Control Capability*

*Video Signal Input/Output Capability*

*Thank you for selecting this YAMAHA stereo receiver.*



## CONTENTS

Safety Instruction .....	2
Warning .....	3
Open/Close the Control Door .....	3
Caution .....	4
Supplied Accessories .....	4
Connections .....	5
Operations .....	8
Tuning Operations .....	10
Remote-Control Transmitter .....	12
Notes about the Remote-Control Transmitter .....	13
Troubleshooting .....	13
Specifications .....	14

OWNER'S MANUAL



# SAFETY INSTRUCTIONS (U.S.A.)

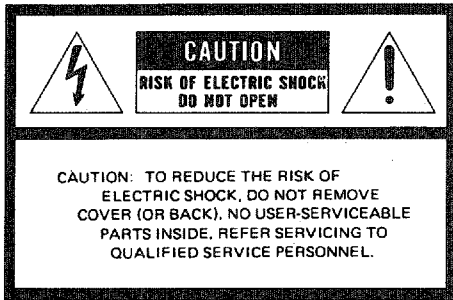

• Explanation of Graphical Symbols



The lightning flash with arrowhead symbol, within an equilateral triangle, is intended to alert you to the presence of uninsulated "dangerous voltage" within the product's enclosure that may be of sufficient magnitude to constitute a risk of electric shock to persons.

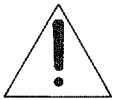

The exclamation point within an equilateral triangle is intended to alert you to the presence of important operating and maintenance (servicing) instructions in the literature accompanying the appliance.

- 1 Read Instructions – All the safety and operating instructions should be read before the unit is operated.
- 2 Retain Instructions – The safety and operating instructions should be retained for future reference.
- 3 Heed Warnings – All warnings on the unit and in the operating instructions should be adhered to.
- 4 Follow Instructions – All operating and other instructions should be followed.
- 5 Water and Moisture – The unit should not be used near water – for example, near a bathtub, washbowl, kitchen sink, laundry tub, in a wet basement, or near a swimming pool, etc.
- 6 Carts and Stands – The unit should be used only with a cart or stand that is recommended by the manufacturer.
- 6A A unit and cart combination should be moved with care. Quick stops, excessive force, and uneven surfaces may cause the unit and cart combination to overturn.
- 7 Wall or Ceiling Mounting – The unit should be mounted to a wall or ceiling only as recommended by the manufacturer.
- 8 Ventilation – The unit should be situated so that its location or position does not interfere with its proper ventilation. For example, the unit should not be situated on a bed, sofa, rug, or similar surface, that may block the ventilation openings; or placed in a built-in installation, such as a bookcase or cabinet that may impede the flow of air through the ventilation openings.
- 9 Heat – The unit should be situated away from heat sources such as radiators, stoves, or other units that produce heat.



- 10 Power Sources – The unit should be connected to a power supply only of the type described in the operating instructions or as marked on the unit.
- 11 Power-Cord Protection – Power-supply cords should be routed so that they are not likely to be walked on or pinched by items placed upon or against them, paying particular attention to cords at plugs, convenience receptacles, and the point where they exit from the unit.
- 12 Cleaning – The unit should be cleaned only as recommended by the manufacturer.
- 13 Nonuse Periods – The power cord of the unit should be unplugged from the outlet when left unused for a long period of time.
- 14 Object and Liquid Entry – Care should be taken so that objects do not fall into and liquids are not spilled into the inside of the unit.
- 15 Damage Requiring Service – The unit should be serviced by qualified service personnel when:
  - A. The power-supply cord or the plug has been damaged; or
  - B. Objects have fallen, or liquid has been spilled into the unit; or
  - C. The unit has been exposed to rain; or
  - D. The unit does not appear to operate normally or exhibits a marked change in performance; or
  - E. The unit has been dropped, or the cabinet damaged.
- 16 Servicing – The user should not attempt to service the unit beyond those means described in the operating instructions. All other servicing should be referred to qualified service personnel.
- 17 Power Lines – An outdoor antenna should be located away from power lines.
- 18 Grounding or Polarization – Precautions should be taken so that the grounding or polarization is not defeated.
- 19 Outdoor Antenna Grounding – If an outside antenna is connected to this unit, be sure the antenna system is grounded so as to provide some protection against voltage surges and built-up static charges. Article 810 of the National Electrical Code, ANSI/NFPA 70, provides information with regard to proper grounding of the mast and supporting structure, grounding of the lead-in wire to an antenna discharge unit, size of grounding conductors, location of antenna discharge unit, connection to grounding electrodes, and requirements for the grounding electrode.

EXAMPLE OF ANTENNA GROUNDING

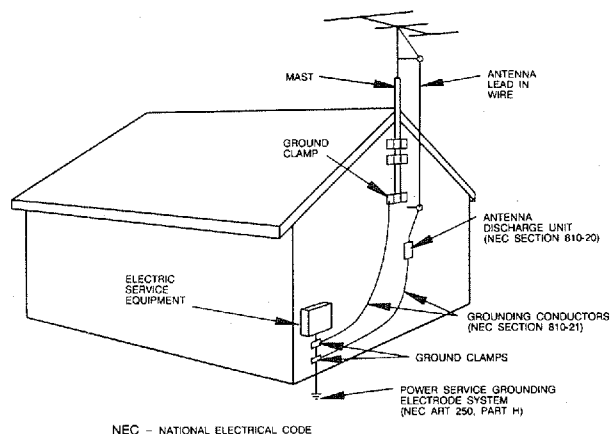

NEC – NATIONAL ELECTRICAL CODE

**Note to CATV system installer:**

This reminder is provided to call the CATV system installer's attention to Article 820-40 of the NEC that provides guidelines for proper grounding and, in

particular, specifies that the cable ground shall be connected to the grounding system of the building, as close to the point of cable entry as practical.

**FCC INFORMATION (U.S.A.)**

**1. IMPORTANT NOTICE : DO NOT MODIFY THIS UNIT!**

This product, when installed as indicated in the instructions contained in this manual, meets FCC requirements. Modifications not expressly approved by Yamaha may void your authority, granted by the FCC, to use the product.

**2. IMPORTANT :** When connecting this product to accessories and/or another product use only high quality shielded cables. Cable/s supplied with this product **MUST** be used. Follow all installation instructions. Failure to follow instructions could void your FCC authorization to use this product in the USA.

**3. NOTE :** This product has been tested and found to comply with the requirements listed in FCC Regulations, Part 15 for Class "B" digital devices. Compliance with these requirements provides a reasonable level of assurance that your use of this product in a residential environment will not result in harmful interference with other electronic devices. This equipment generates/uses radio frequencies and, if not installed and used according to the instructions found in the users manual, may cause interference harmful to the operation of other electronic devices.

Compliance with FCC regulations does not guarantee that interference will not occur in all installations. If this product is found to be the source of interference, which can be determined by turning the unit "OFF" and "ON", please try to eliminate the problem by using one of the following measures:

Relocate either this product or the device that is being affected by the interference.

Utilize power outlets that are on different branch (circuit breaker or fuse) circuits or install AC line filter/s.

In the case of radio or TV interference, relocate/reorient the antenna. If the antenna lead-in is 300 ohm ribbon lead, change the lead-in to co-axial type cable.

If these corrective measures do not produce satisfactory results, please contact the local retailer authorized to distribute this type of product. If you can not locate the appropriate retailer, please contact Yamaha Electronics Corp., U.S.A. 6722 Orangethorpe Ave, Buena Park, CA 90620.

The above statements apply **ONLY** to those products distributed by Yamaha Corporation of America or its subsidiaries.

**WARNING: CHEMICAL CONTENT NOTICE! (U.S.A.)**

The solder used in the manufacture of this product contains LEAD. In addition, the electrical/electronic and/or plastic (where applicable) components may also contain traces of chemicals found by the California Health and Welfare Agency (and possibly other entities) to cause cancer and/or birth defects or other reproductive harm.

**IMPORTANT MESSAGE:** Yamaha strives to produce products that are both user safe and environmentally "friendly". We sincerely believe that our products meet these goals. However, in keeping with both the spirit and the letter of various statutes we have included the preceding messages and others in various locations in this manual.

**DO NOT REMOVE ANY ENCLOSURE COMPONENTS!**

There are no user serviceable parts inside. All service should be performed by a service representative authorized by Yamaha to perform such service.

**OPEN/CLOSE THE CONTROL DOOR**

When it is not necessary to operate controls inside the control door, close the door.

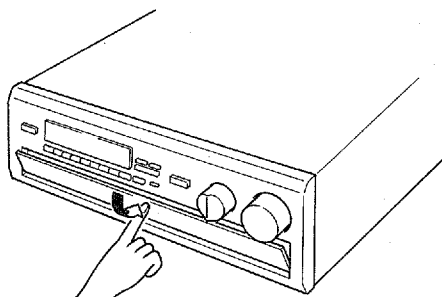

To open the door

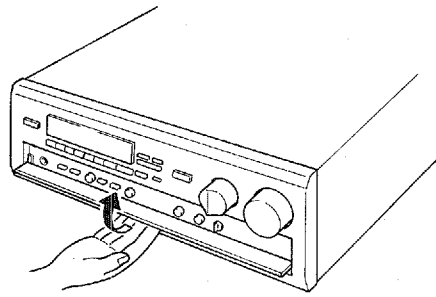

To close the door

## CAUTION: READ THIS BEFORE OPERATING YOUR UNIT.

1. To assure the finest performance, please read this manual carefully. Keep it in a safe place for future reference.
2. Install this unit in a cool, dry, clean place – away from windows, heat sources, sources of excessive vibration, dust, moisture and cold. Avoid sources of humming (transformers, motors). To prevent fire or electrical shock, do not expose the unit to rain or water.
3. Never open the cabinet. If something drops into the set, contact your dealer.
4. Do not use force on switches, controls or connection wires. When moving the unit, first disconnect the power plug and the wires connected to other equipment. Never pull the wire itself.
5. The openings on the cabinet assure proper ventilation of this unit. If these openings are obstructed, the temperature inside the cabinet will rise rapidly and eventually damage the circuits. Therefore, avoid placing objects against these openings and do not install this unit where the flow of air through the ventilation openings could be impeded.
6. Always set the VOLUME control to “-∞” before starting the audio source play: increase the volume gradually to an appropriate level after the play has been started.
7. Do not attempt to clean the unit with chemical solvents; this might damage the finish. Use a clean, dry cloth.
8. Be sure to read the “TROUBLESHOOTING” section regarding common operating errors before concluding that the unit is faulty.
9. When not planning to use this unit for long periods of time (ie., vacation, etc.), disconnect the AC power plug from the wall outlet.
10. To prevent lightning damage, disconnect the AC power plug and disconnect the antenna cable when there is an electrical storm.
11. Grounding or polarization – Precautions should be taken so that the grounding or polarization of an appliance is not defeated.
12. AC outlet  
Do not connect audio equipment to the AC outlet on the rear panel if that equipment requires more power than the outlet is rated to provide.
13. **Voltage Selector (General Model only)**  
The voltage selector on the rear panel of this unit must be set for your local main voltage BEFORE plugging into the AC main supply.  
Voltages are 110/120/220/240V AC, 50/60 Hz.

### IMPORTANT

Please record the serial number of this unit in the space below.

Serial No.:

The serial number is located on the rear of the unit. Retain this Owner's Manual in a safe place for future reference.

### WARNING

TO REDUCE THE RISK OF FIRE OR ELECTRIC SHOCK, DO NOT EXPOSE THIS UNIT TO RAIN OR MOISTURE.

### CAUTION (FOR CANADA MODEL)

TO PREVENT ELECTRIC SHOCK DO NOT USE THIS (POLARIZED) PLUG WITH AN EXTENSION CORD RECEPTACLE OR OTHER OUTLET UNLESS THE BLADES CAN BE FULLY INSERTED TO PREVENT BLADE EXPOSURE.

### FOR CANADIAN CUSTOMER

THIS DIGITAL APPARATUS DOES NOT EXCEED THE “CLASS B” LIMITS FOR RADIO NOISE EMISSIONS FROM DIGITAL APPARATUS SET OUT IN THE RADIO INTERFERENCE REGULATION OF THE CANADIAN DEPARTMENT OF COMMUNICATIONS.

The power switch does not disconnect the complete apparatus from the mains line.

### Special Instructions for U.K. Model

### IMPORTANT

THE WIRES IN THE MAINS LEAD ARE COLOURED IN ACCORDANCE WITH THE FOLLOWING CODE:

Blue: NEUTRAL  
Brown: LIVE

The colours of the wires in the mains lead of this apparatus may not correspond with the coloured markings identifying the terminals in your plug. Proceed as follows: the wire which is coloured BLUE must be connected to the terminal which is marked with the letter N or coloured BLACK. The wire which is coloured BROWN must be connected to the terminal which is marked with the letter L or coloured RED. Making sure that neither core is connected to the earth terminal of the three pin plug.

### FREQUENCY STEP switch (General Model only)

Because the interstation frequency spacing differs in different areas, set the FREQUENCY STEP switch (located at the rear) according to the frequency spacing in your area. Before setting this switch, disconnect the AC power plug of this unit from the AC outlet.

## SUPPLIED ACCESSORIES

After unpacking, check that the following parts are contained.

Indoor FM Antenna

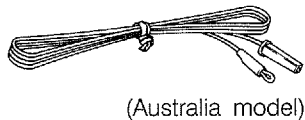
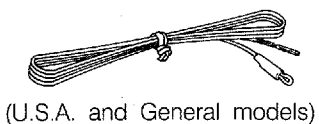

AM Loop Antenna

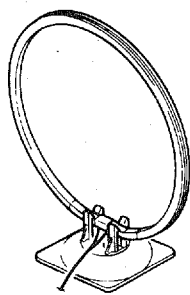

Remote Control Transmitter

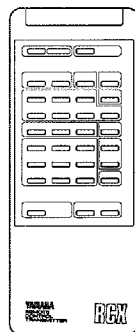

Batteries (size “AA”, R6)

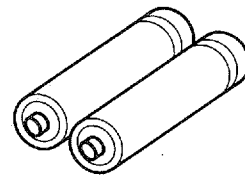

# CONNECTIONS

Before attempting to make any connections to or from this unit, be sure to first switch OFF the power to this unit and to any other components to which connections are being made.

## CONNECTIONS WITH OTHER COMPONENTS

When making connections between this unit and other components, be sure all connections are made correctly, that is to say L (left) to L, R (right) to R, "+" to "+" and "-" to "-". Also, refer to the owner's manual for each component to be connected to this unit.

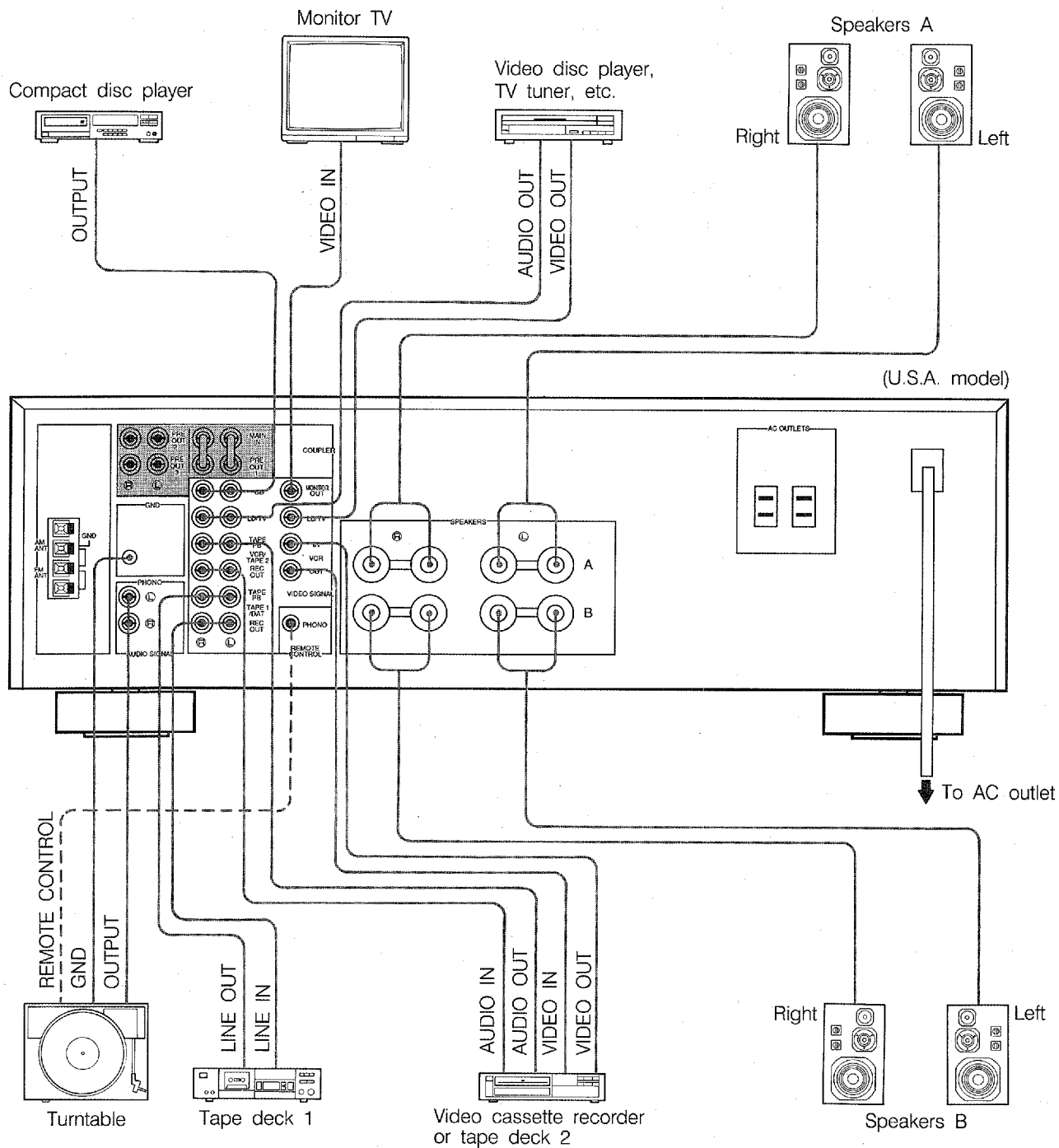

 : Refer to "COUPLER terminals" on the page 6.

### Connecting speaker systems

- One or two speaker systems can be connected to this unit. If you connect only one speaker system, connect it to either **SPEAKERS A** or **B** terminals.
- Use speakers with the specified impedance shown on the rear of this unit.
- **How to Connect:**  
Connect the **SPEAKERS** terminals to your speakers with wire of the proper gauge, cut to be as short as possible. If the connections are faulty, no sound will be heard from the speakers. Make sure that the polarity of the speaker wires is correct, that is, + and - markings are observed. If these wires are reversed, the sound will be unnatural and will lack bass. **Do not let the bare speaker wires touch each other or do not let them touch the metal parts of this unit as this could damage this unit and/or speakers.**

Red: positive (+)  
Black: negative (-)

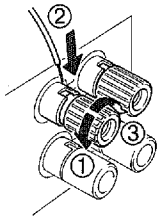

- ① Unscrew the knob.
- ② Insert the bare wire.
- ③ Tighten the knob and secure the wire.

\* Banana Plug connections are also possible. Simply insert the Banana Plug connector into the corresponding terminal.

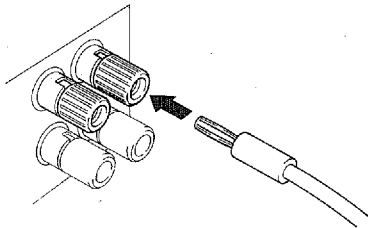

### About the accessory terminals

#### AC OUTLETS

(U.S.A. and General models) .....2 SWITCHED OUTLETS  
(Australia model) ..... 1 SWITCHED OUTLET

Use these to connect the power cords from your components to this unit.

The power to the **SWITCHED** outlets is controlled by this unit's **POWER** switch. They will supply power to any component whenever this unit is turned on.

The maximum power (total power consumption of components) that can be connected to the **SWITCHED AC OUTLETS** is 200 watts.

#### REMOTE CONTROL (PHONO) connector

If you have a YAMAHA turntable with the **RSB** mark, connect it to this connector by using the cable provided with the turntable. This connection allows you to control the turntable from the provided remote control transmitter.

#### GND terminal (For turntable use)

Connecting the ground wire of the turntable to this terminal will generally minimize hum, but in some cases better results may be obtained with the ground wire disconnected.

### COUPLER terminals

#### PRE OUT 1/MAIN IN terminals

Removing the jumper pins enables this unit to independently perform the functions of a control amplifier and a power amplifier. These terminals are for connection of a signal-processing system such as a graphic equalizer or sound processor.

To connect such a unit, remove the jumper pins from the **PRE OUT 1/MAIN IN** terminals, connect the inputs of that unit to the **PRE OUT 1** terminals and its outputs to the **MAIN IN** terminals. The Owner's Manual included with the unit may have detailed informations.

Once the unit is connected, the **VOLUME** control of this unit can be used for overall adjustment of the level of sound.

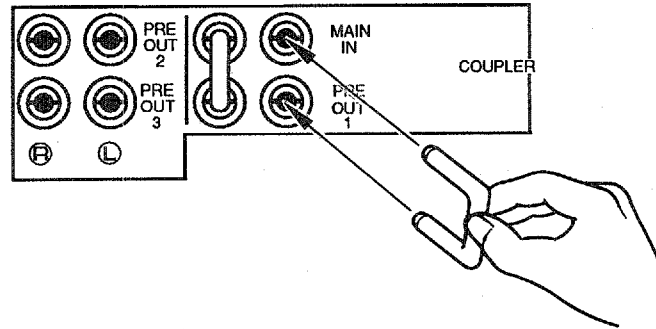

#### PRE OUT 2/PRE OUT 3 terminals

These are auxiliary output terminals for connecting external power amplifier etc.

By Connecting two external power amplifiers to this unit using these terminals, you can construct a 6-room multi-zone system where each room has the same source and volume.

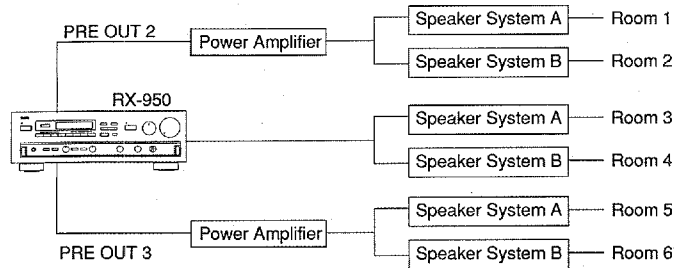

# ANTENNA CONNECTIONS

- Each antenna should be connected to the designated terminals correctly, referring to the following figure.
- Both AM and FM indoor antennas are included with this unit. In general, these antennas will probably provide sufficient signal strength. Nevertheless, a properly installed outdoor antenna will give clearer reception than an indoor one. If you experience poor reception quality, an outdoor antenna may result in improvement.

## U.S.A. AND GENERAL MODELS

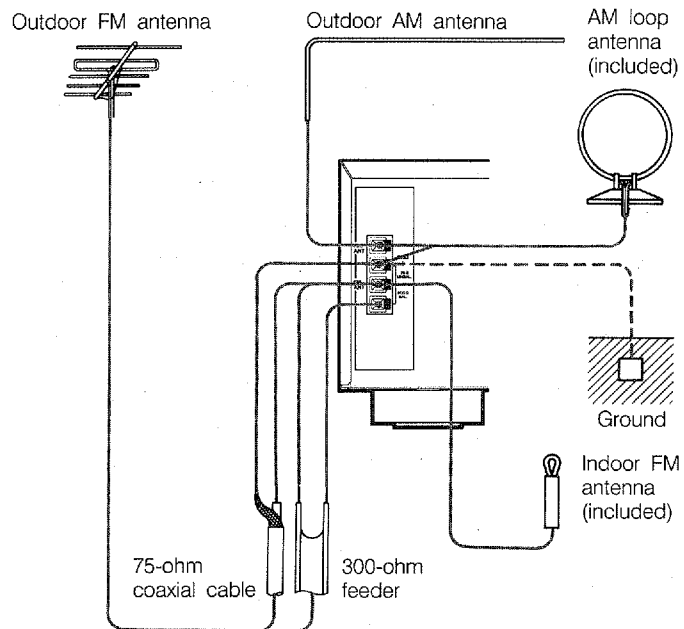

## AUSTRALIA MODEL

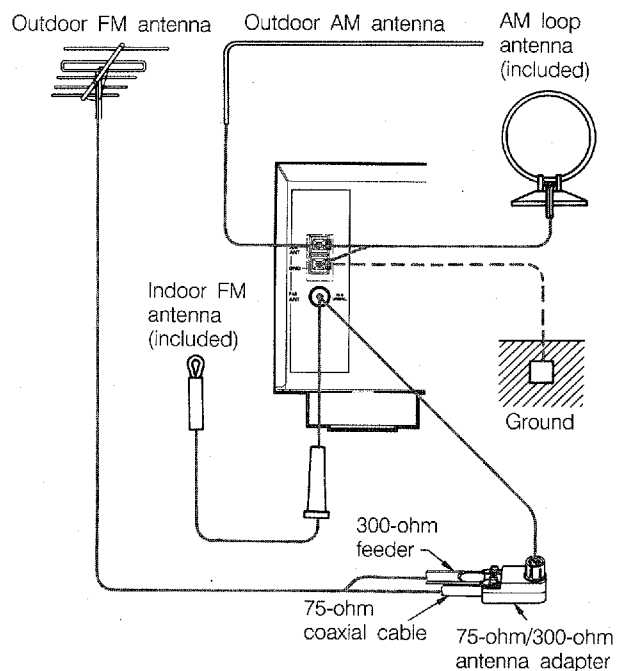

### Connecting the AM loop antenna

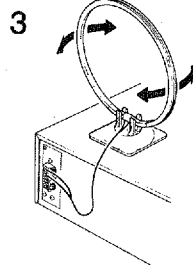
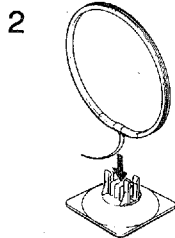
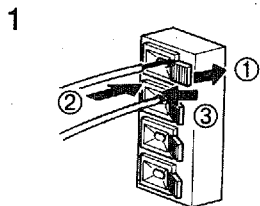

Orient so that the best reception is obtained.

- \* The antenna may be hung on a wall.
- \* The AM loop antenna should be kept connected, even if an outdoor AM antenna is connected to this unit.

### GND terminal

For maximum safety and minimum interference, connect the **GND** terminal to a good earth ground. A good earth ground is a metal stake driven into moist earth.

### Notes

- When connecting the indoor FM antenna (for Australia model), make sure that the grooved part of the connector hole is facing downward.
- If you need an outdoor FM antenna to improve FM reception quality, either 300-ohm feeder or coaxial cable may be used. In locations troubled by electrical interference, coaxial cable is preferable.

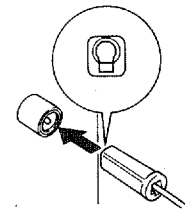

# OPERATIONS

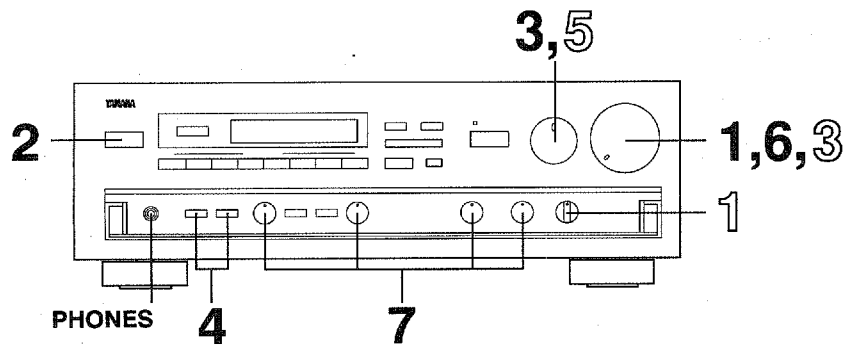

## To play a source

<b>1</b>	<p style="text-align: center;">VOLUME</p> <p style="text-align: center;">Set to the "∞" position.</p>
<b>2</b>	<p style="text-align: center;">POWER</p>
<b>3</b>	<p>Select a desired input source.</p>
<b>4</b>	<p>Select the speaker system to be used by pressing the <b>SPEAKERS</b> switches. (Refer to the next page for details.)</p>
<b>5</b>	<p>Play the source. (For detailed information on the tuning operation, refer to the page 10.)</p>
<b>6</b>	<p style="text-align: center;">VOLUME</p> <p style="text-align: center;">Adjust to the desired output level.</p>

**7** If desired, adjust the **BASS, TREBLE, BALANCE, LOUDNESS** controls, etc. (Refer to the next page for details.)

## To record a source to tape (or dub from one tape to another)

<b>1</b>	<p>Select the source to be recorded.</p>
<b>2</b>	<p>Play the source.</p>
<b>3</b>	<p>Confirm the source by selecting it with the <b>INPUT</b> selector and turning up the <b>VOLUME</b> control.</p>
<b>4</b>	<p>Set the tape deck (or VCR) in the recording mode.</p>
<b>5</b>	<p>If your tape deck has three head monitoring capability you can monitor the signal just recorded by selecting the corresponding tape source.</p>

\* For details, refer to the manual of the tape deck being used.

### Notes

- If you want to enjoy another source while recording, select it with the **INPUT** selector.
- Adjusting the **VOLUME, LOUDNESS, BASS, TREBLE** controls, **TURNOVER FREQUENCY** switch, **BALANCE** control and **PURE DIRECT** switch during recording has no effect on the material being recorded.



## Adjusting the BALANCE control

Adjust the balance of the output volume to the left and right speakers to compensate for sound imbalance caused from speaker location or listening room conditions.

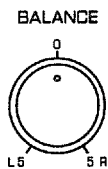

## Adjusting the BASS and TREBLE controls

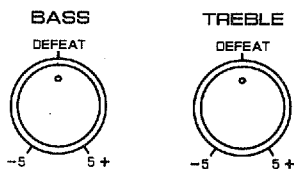

**BASS** : Turn this clockwise to increase (or counter-clockwise to decrease) the low frequency response.

**TREBLE** : Turn this clockwise to increase (or counter-clockwise to decrease) the high frequency response.

## Using the TURNOVER FREQUENCY switches

These switches can be used to adjust the turnover point of the tone controls: either 200 Hz or 400 Hz for **BASS** and either 2.5 kHz or 5 kHz for **TREBLE**. This gives you flexible control over bass and treble response characteristics.

TURNOVER FREQUENCY

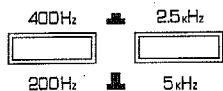

## Using the PURE DIRECT switch

You can enjoy the purest possible sound from your audio sources by setting this switch so that the indicator illuminates. By doing so, the audio signal bypasses the **TURNOVER FREQUENCY, BASS, TREBLE, BALANCE** and **LOUDNESS** controls, eliminating any alterations to the audio signal.

### Note

When this switch is on, the purest sound is output from the **PRE OUT 1/2/3** terminals. However, a sound processor, equalizer, etc. connected between the **PREOUT1** and **MAIN IN** terminals becomes ineffective.

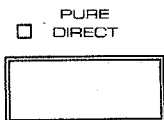

## Selecting the SPEAKER system

Because one or two speaker systems can be connected to this unit, the **SPEAKERS** switches allow you to select speaker system A or B or both at once.

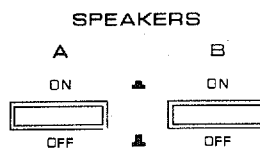

## Adjusting the continuously variable LOUDNESS control

This control provides compensation for the human ears' loss of sensitivity to high and low-frequency ranges at low volume. This control is adjustable to retain full tonal range at any volume level.

### 1 LOUDNESS

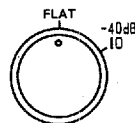

Set to the "FLAT" position.

### 2 VOLUME

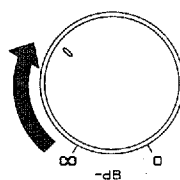

Set to the loudest listening level that you would listen to.

### 3 LOUDNESS

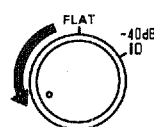

Turn so that the desired volume level can be achieved.

## When you listen with headphones

Connect the headphones to the **PHONES** jack. When listening with headphones privately, set both the **SPEAKERS A** and **B** switches to the OFF position.

PHONES

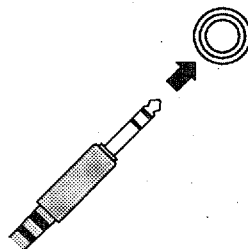

# TUNING OPERATIONS

Normally, if station signals are strong and there is no interference, quick automatic-search tuning (AUTOMATIC TUNING) is possible. However, if signals of the station you want to select are weak, you must tune to it manually (MANUAL TUNING).

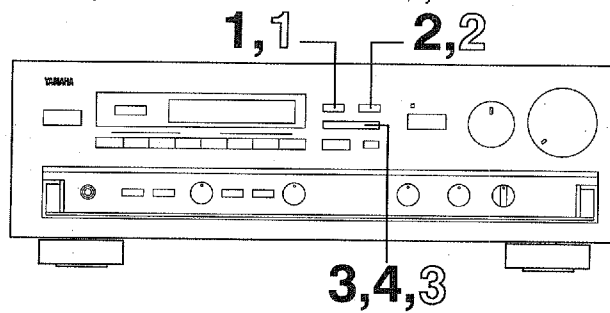

## AUTOMATIC TUNING

- 1** Select the reception band (FM or AM) while watching the display.

FM/AM
- 2** TUNING MODE AUTO/MAN'L MONO
- 3**

To tune to a higher frequency, press the right side once.  
To tune to a lower frequency, press the left side once.
- 4** If the station where tuning search stopped is not the desired one, follow step 3 again.

\* If the tuning search does not stop at the desired station (because the signals of the station are weak), change to the MANUAL TUNING method.

## MANUAL TUNING

- 1** Select the reception band (FM or AM) while watching the display.

FM/AM
- 2** TUNING MODE AUTO/MAN'L MONO
- 3** Tune to a desired station manually.

\*To continue tuning search, press and hold the button.

### Note

If you tune to a FM station manually, it is received in monaural automatically to increase the signal quality.

## Display information

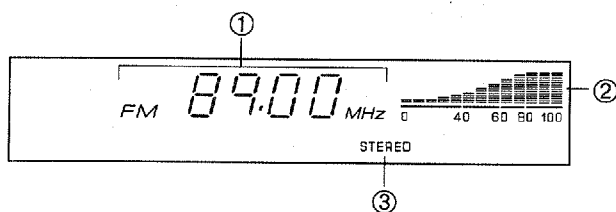

- ① Displays the band and frequency of the received station.
- ② Indicates the signal level of the received station.
- ③ Illuminates when an FM stereo broadcast with sufficient signal strength is received.

# PRESET TUNING

This unit can store station frequencies (selected by tuning operation) by using the preset station buttons. With this function, you can select any desired station by only pressing the corresponding preset station button. Up to 40 stations (8 stations per page) can be stored.

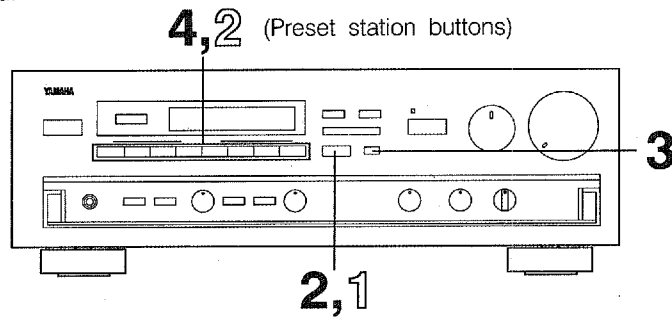

## To program stations

- 1 Tune to a desired station.  
(Refer to the previous page for tuning procedures.)
- 2 Select a desired page (A – E) of preset station buttons while watching the display.
- 3
 

Flashes on and off for about 5 seconds.
- 4 Press a preset station button before "MEMORY" goes off from the display.
 

Shows the displayed station has been programmed to A1.

\* In the same way, program other stations to A2, A3 ... A8.  
\* You can program more stations to the preset station buttons on other pages in the same way by selecting other pages in step 2.

## To recall a preset station

- 1 Select the page of preset station buttons.
- 2
 

Select the desired preset station button.

### Notes

- A new setting can be programmed in place of the former one.
- For presets, the setting of the reception mode (stereo or monaural) is stored along with the station frequency.

### Memory back-up

The memory back-up circuit prevents the programmed data from being lost even if the **POWER** switch is set off or the power plug is disconnected from the AC outlet or the power is cut due to temporary power failure. If, however, the power is cut for more than one week, the memory may be erased. If so, it can be re-programmed by simply following the PRESET TUNING steps.

# REMOTE-CONTROL TRANSMITTER

The remote-control transmitter provided with this unit is designed to control all the most commonly used functions of the unit. If the CD player, turntable, equalizer, and tape deck connected to this unit are YAMAHA components designed for remote control compatibility (components with an *RS* mark), then this remote-control transmitter will also control various functions of each component. Please consult your authorized YAMAHA dealer for information on which components are compatible with the remote-control transmitter.

## Key Functions

### For Receiver Control

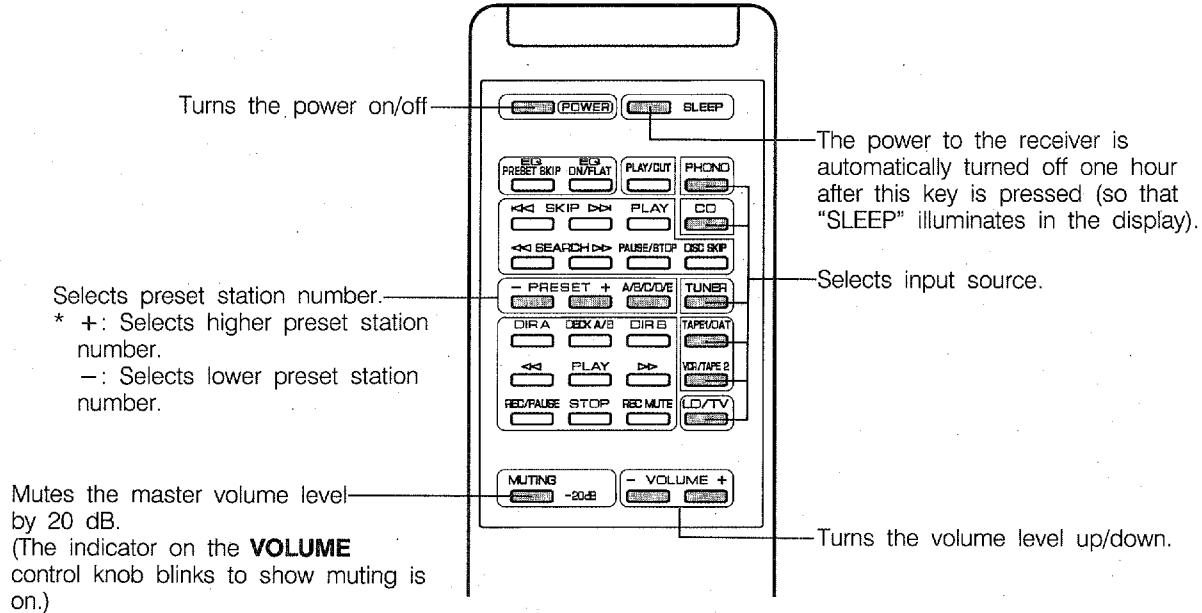

### For Other Component Control

Identify the remote-control transmitter keys with your component's keys. If these keys are identical, their function will be the same. On each key function, refer to the corresponding instruction on your component's manual.

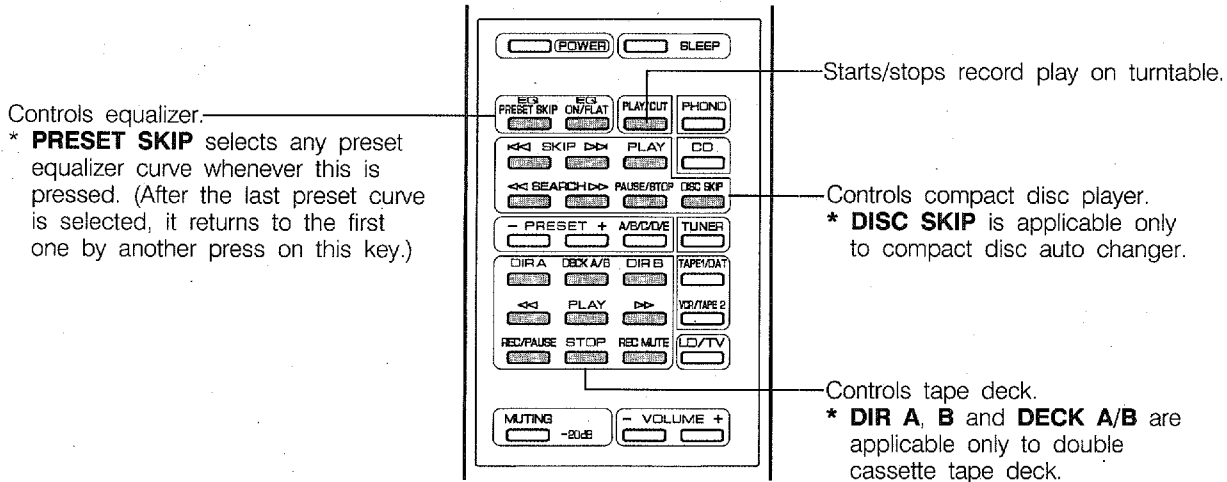

# NOTES ABOUT THE REMOTE-CONTROL TRANSMITTER

## Battery installation

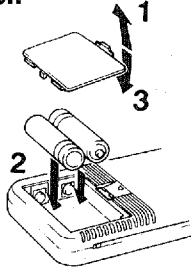

## Battery replacement

If the remote-control transmitter must be used closer to the main unit, the batteries are weak. Replace both batteries with new ones.

### Notes

- Use only "AA" (R6) batteries for replacement.
- Be sure the polarities are correct. (See the illustration inside the battery compartment.)
- Remove the batteries if the remote-control transmitter will not be used for an extended period of time.
- If batteries leak, immediately dispose of them. Avoid touching the leaked material or letting it come in contact with clothing, etc. Clean the battery compartment thoroughly before installing new batteries.

## Remote-control transmitter operation range

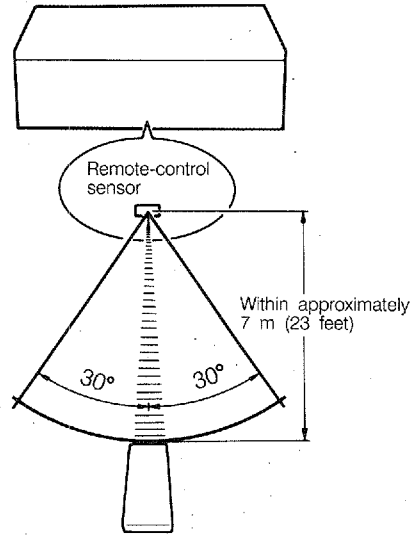

### Notes

- There should be no large obstacles between the remote-control transmitter and the main unit.
- If the remote control sensor is directly illuminated by strong lighting (or an inverter type of fluorescent lamp etc.), it may happen that the remote-control transmitter does not work correctly. In this case, change the position of the main unit to avoid being lit directly.

# TROUBLESHOOTING

If the unit fails to operate normally, check the following points to determine whether the fault can be corrected by the simple measures suggested. If it cannot be corrected, or if the fault is not listed in the SYMPTOM column, disconnect the power cord and contact your authorized YAMAHA dealer or service center for help.

	SYMPTOM	CAUSE	REMEDY
Amplifier	The receiver fails to turn on when the POWER switch is pressed.	Power cord is not plugged in or is not completely inserted.	Firmly plug in the power cord.
	No sound.	Incorrect output cord connections.	Connect cord properly. If the problem persists, the cables may be defective.
		Incorrect input selection.	Set the INPUT selector to the correct input selection.
	Using the BASS, TREBLE, TURNOVER FREQUENCY, BALANCE, and LOUDNESS controls does not affect the tone. The components connected to the COUPLER terminals do not function.	The PURE DIRECT switch is ON.	The PURE DIRECT switch must be switched OFF to use the controls.
	Sound "hums".	Incorrect cord connections.	Firmly connect the audio plugs. If the problem persists, the cord may be defective.
	Sound level is low.	The LOUDNESS control is functioning.	Set the LOUDNESS control to the FLAT position.
The MUTING key is set on. (When this key is on, the indicator on the VOLUME control is blinking.)		Press the MUTING key on the remote-control transmitter to set the key off.	
The remote-control transmitter does not work.	Direct sunlight or lighting (of an inverter type of fluorescent lamp etc.) is striking the remote control sensor of the main unit.	change position of the main unit.	
FM	FM stereo reception is noisy.	Because of the characteristics of FM stereo broadcasts, this is limited to cases where the transmitter is far away or the antenna input is poor.	Check the antenna connections. Try using a multiple element FM antenna.
	There is distortion and clear reception cannot be obtained even with a good FM antenna.	There is multipath interference.	Adjust antenna placement to eliminate multipath interference.
	A desired station cannot be tuned in with Auto tuning.	The station is too weak.	Use Manual tuning mode. Use high quality directional FM antenna.
AM	A desired station cannot be tuned in with Auto tuning.	Weak signal or loose antenna connections.	Tighten the AM loop antenna connections and rotate it for best reception. Use Manual tuning mode.
	There are continuous crackling and hissing noises.	These noises result from lightning, fluorescent lamps, motors, thermostats and other electrical equipment.	Use an outdoor antenna and a ground wire. This will help some what but it is difficult to eliminate all noise.
	There are buzzing and whining noises (especially in the evening).	A television set is being used nearby.	Move the television away.

# SPECIFICATIONS

## AUDIO SECTION

Minimum RMS Output Power per Channel  
 8 ohms, 20 Hz to 20 kHz, 0.015% THD ... 120W  
 Dynamic Power per Channel (IHF)  
 8/6/4/2 ohms ..... 160/190/210/340W  
 Dynamic Headroom  
 [U.S.A. and General models] ..... 1.25 dB  
 Power Band Width  
 8 ohms, 60W, 0.1% THD ..... 10 Hz to 50 kHz  
 Damping Factor  
 8 ohms, 1 kHz ..... 200 or more  
 Input Sensitivity/Impedance  
 PHONO ..... 2.5 mV/47 k-ohms  
 CD/TAPE/VCR/LD-TV/DAT ..... 150 mV/47 k-ohms  
 MAIN IN ..... 1V/47 k-ohms  
 Maximum Input Signal Level (1 kHz, 0.01% THD)  
 PHONO ..... 115 mV  
 Output Level/Impedance  
 REC OUT ..... 150 mV/220 ohms  
 PRE OUT ..... 1V/100 ohms  
 Maximum Voltage Output (PRE OUT)  
 20 Hz to 20 kHz, 0.02% THD ..... 4V  
 Headphone Jack Rated Output/Impedance  
 8 ohms, 0.01% THD ..... 0.5V/220 ohms  
 Frequency Response (20 Hz to 20 kHz)  
 CD/TAPE/VCR/LD-TV/DAT/MAIN IN  
 ..... +0, -0.3 dB  
 RIAA Equalization Deviation  
 PHONO ..... ±0.3 dB  
 Total Harmonic Distortion (20 Hz to 20 kHz)  
 PHONO to REC OUT (3V) ..... 0.005%  
 CD/TAPE/VCR/LD-TV/DAT to PRE OUT (1V)  
 ..... 0.005%  
 CD/TAPE/VCR/LD-TV/MAIN IN to SP OUT  
 (60W/8 ohms) ..... 0.008%  
 Intermodulation Distortion  
 CD/TAPE/VCR/LD-TV/DAT (Rated Output/8 ohms)  
 ..... 0.01%  
 Signal-to-Noise Ratio (IHF-A Network) (Pure Direct  
 Switch : ON)  
 PHONO (5 mV Input Shorted) ..... 92 dB  
 CD/TAPE/VCR/LD-TV/DAT (Shorted) ..... 110 dB  
 Residual Noise (IHF-A Network)  
 (Pure Direct Switch: ON) ..... 90 µV

Channel Separation (1 kHz/10 kHz, Vol. -30 dB)  
 PHONO (Input Shorted) ..... 75/55 dB  
 CD/TAPE/VCR/LD-TV/DAT  
 (Input 5.1 k-ohms Terminated) ..... 75/55 dB  
 Tone Control Characteristics  
 BASS: Boost/cut ..... ±10 dB (20 Hz)  
 Turnover Frequency ..... 200, 400 Hz  
 TREBLE: Boost/cut ..... ±10 dB (20 kHz)  
 Turnover Frequency ..... 2.5, 5 kHz  
 Continuous Loudness Control ..... -40 dB (1 kHz)  
 (Level related equalization)  
 Audio Muting ..... -20 dB

## VIDEO SECTION

Input Sensitivity/Impedance ..... 1V/75 ohms  
 Output Level/Impedance ..... 1V/75 ohms

## FM SECTION

Tuning Range  
 [U.S.A. and General models]  
 ..... 87.5 to 107.9 MHz  
 [Australia and General models]  
 ..... 87.5 to 108.0 MHz  
 50 dB Quieting Sensitivity (IHF, 75 ohms)  
 Mono ..... 1.55 µV (15.1 dBf)  
 Stereo ..... 21 µV (37.7 dBf)  
 Usable Sensitivity (75 ohms) ..... 0.8 µV (9.3 dBf)  
 (30 dB S/N Quieting, 1 kHz, 100% mod.)  
 Image Response Ratio ..... 45 dB  
 IF Response Ratio ..... 80 dB  
 Spurious Response Ratio ..... 70 dB  
 AM Suppression Ratio ..... 55 dB  
 Capture Ratio ..... 1.5 dB  
 Alternate Channel Selectivity ..... 85 dB  
 Signal-to-Noise Ratio  
 (IHF) Mono/Stereo ..... 81/76 dB  
 Harmonic Distortion  
 Mono ..... 0.1%  
 Stereo Separation (1 kHz) ..... 50 dB

Frequency Response  
 30 Hz to 15 kHz ..... 0± 1.5 dB

## AM SECTION

Tuning Range  
 [U.S.A. and General models]  
 ..... 530 to 1,710 kHz  
 [Australia and General models]  
 ..... 531 to 1,611 kHz  
 Usable Sensitivity ..... 100 µV/m  
 Selectivity ..... 32 dB  
 Signal-to-Noise Ratio ..... 50 dB  
 Image Response Ratio ..... 40 dB  
 Spurious Response Ratio ..... 50 dB  
 Harmonic Distortion (400 Hz) ..... 0.3%

## AUDIO SECTION

Output Level/Impedance  
 FM (100% mod., 1 kHz) ..... 700 mV/2.9 k-ohms  
 AM (30% mod., 400 Hz) ..... 200 mV/2.9 k-ohms

## GENERAL

Power Supply  
 [U.S.A. model] ..... AC 120V, 60 Hz  
 [Australia model] ..... AC 240V, 50 Hz  
 [General model]  
 ..... AC 110/120/220/240V, 60/50 Hz  
 Power Consumption  
 [U.S.A. model] ..... 400W  
 [Australia and General models] ..... 330W  
 AC Outlets  
 [U.S.A. and General models]  
 2 Switched ..... 200W max.  
 [Australia, model]  
 1 Switched ..... 200W max.  
 Dimensions (W × H × D)  
 ..... 435 × 171 × 448 mm  
 (17-1/8" × 6-3/4" × 17-5/8")  
 Weight ..... 15.1 kg (33 lbs. 4 oz.)  
 Accessories ..... AM loop antenna  
 Indoor FM antenna  
 Remote control transmitter  
 Batteries

Specifications subject to change without notice.



# YAMAHA

---

**YAMAHA ELECTRONICS CORPORATION, USA** 6722 ORANGETHORPE AVE., BUENA PARK, CALIF. 90620, U.S.A.  
**YAMAHA CANADA MUSIC LTD.** 135 MILNER AVE., SCARBOROUGH, ONTARIO M1S 3R1, CANADA  
**YAMAHA ELECTRONIK EUROPA G.m.b.H.** SIEMENSSTR. 22-34, D-2084 RELLINGEN BEI HAMBURG, F.R. OF GERMANY  
**YAMAHA ELECTRONIQUE FRANCE S.A.** 17 RUE DES CAMPANULES, LOGNES 77321 MARNE LA VALLEE CEDEX 2, FRANCE  
**YAMAHA ELECTRONICS (UK) LTD.** YAMAHA HOUSE, 200 RICKMANSWORTH ROAD WATFORD, HERTS WD1 7JS, ENGLAND  
**YAMAHA SCANDINAVIA A.B.** J A WETTERGRENS GATA 1, BOX 30053, 400 43 VÄSTRA FRÖLUNDA, SWEDEN  
**YAMAHA MUSIC AUSTRALIA PTY, LTD.** 17-33 MARKET ST., SOUTH MELBOURNE, 3205 VIC., AUSTRALIA

**YAMAHA CORPORATION**  
VL54180-0 BWVB,V   Printed in Japan.